

ENGLISH

**DDL-8700
INSTRUCTION MANUAL**

CONTENTS

1. SPECIFICATIONS.....	1
2. INSTALLATION	1
3. INSTALLING THE BELT COVER AND THE BOBBIN WINDER	2
4. ADJUSTING THE HEIGHT OF THE KNEE LIFTER	2
5. INSTALLING THE THREAD STAND.....	3
6. LUBRICATION	3
7. ADJUSTING THE AMOUNT OF OIL (OIL SPLASHES) IN THE HOOK.....	4
8. ATTACHING THE NEEDLE.....	5
9. SETTING THE BOBBIN INTO THE BOBBIN CASE.....	5
10. ADJUSTING THE STITCH LENGTH	5
11. PRESSER FOOT PRESSURE.....	6
12. HAND LIFTER.....	6
13. ADJUSTING THE HEIGHT OF THE PRESSER BAR	6
14. THREADING THE MACHINE HEAD	7
15. THREAD TENSION.....	8
16. THREAD TAKE-UP SPRING	8
17. ADJUSTING THE THREAD TAKE-UP STROKE.....	8
18. NEEDLE-TO-HOOK RELATIONSHIP	9
19. HEIGHT OF THE FEED DOG	9
20. TILT OF THE FEED DOG	10
21. ADJUSTING THE FEED TIMING.....	10
22. ADJUSTING THE FEED TIMING (DDL-8700L)	11
23. MOTOR PULLEYS AND BELTS	12

1. SPECIFICATIONS

	DDL-8700	DDL-8700A	DDL-8700H
Application	General fabrics, light-weight and medium-weight materials	General fabrics, light-weight materials	Medium-weight materials, heavy-weight materials
Sewing speed	Max. 5,500 sti/min	Max. 4,000 sti/min	Max. 4,000 sti/min
Stitch length	Max. 5 mm	Max. 4 mm	Max. 5 mm
Needle	DB x 1 #9 to #18 (134 #65 to #110)	DA x 1 #9 to #11 (134 #65 to #75)	DB x 1 #20 to #23 (134 #125 to #160)
Presser foot lift (by knee lifter)	10 mm (Standard) 13 mm (Max.)	9 mm (Max.)	10 mm (Standard) 13 mm (Max.)
Lubricating oil	JUKI New Defrix Oil No. 1		
Noise	- Equivalent continuous emission sound pressure level (L_{pA}) at the workstation : A-weighted value of 83.5 dB; (Includes $K_{pA} = 2.5$ dB); according to ISO 10821- C.6.2 -ISO 11204 GR2 at 5,000 sti/min. - Sound power level (L_{WA}) ; A-weighted value of 88.0 dB; (Includes $K_{WA} = 2.5$ dB); according to ISO 10821- C.6.2 -ISO 3744 GR2 at 5,000 sti/min.		

	DDL-8700L	
Application	For heavy-weight materials	
Sewing speed	3,000 sti/min	Max. 4,000 sti/min (for feed pitch of 5 mm or less) Max. 3,200 sti/min (for feed pitch of 5 mm or more)
Stitch length	Max. 7 mm	
Needle	DB x 1 #20 to #23 (DP x 5 #16 to #18)	
Presser foot lift (by knee lifter)	13 mm (Max.)	
Lubricating oil	JUKI New Defrix Oil No. 1	
Noise	- Equivalent continuous emission sound pressure level (L_{pA}) at the workstation : A-weighted value of 83.5 dB; (Includes $K_{pA} = 2.5$ dB); according to ISO 10821- C.6.2 -ISO 11204 GR2 at 5,000 sti/min. - Sound power level (L_{WA}) ; A-weighted value of 88.0 dB; (Includes $K_{WA} = 2.5$ dB); according to ISO 10821- C.6.2 -ISO 3744 GR2 at 5,000 sti/min.	

2. INSTALLATION

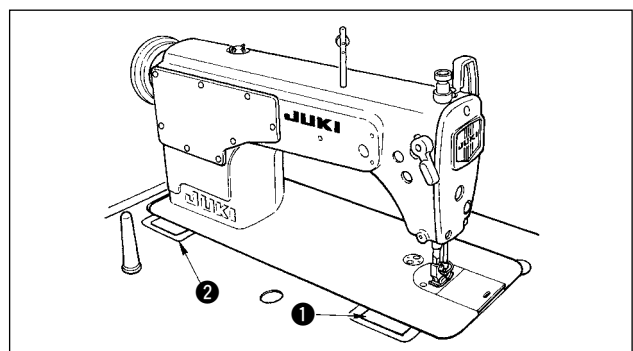
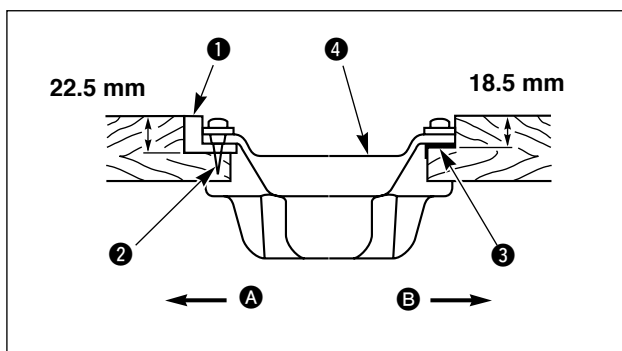
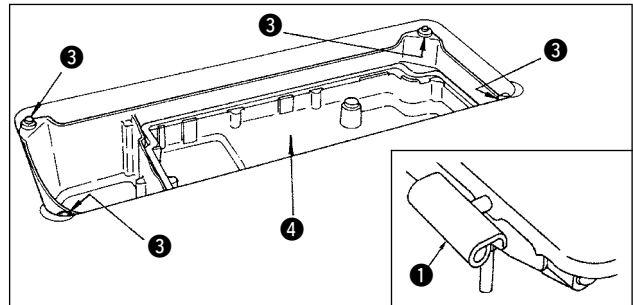
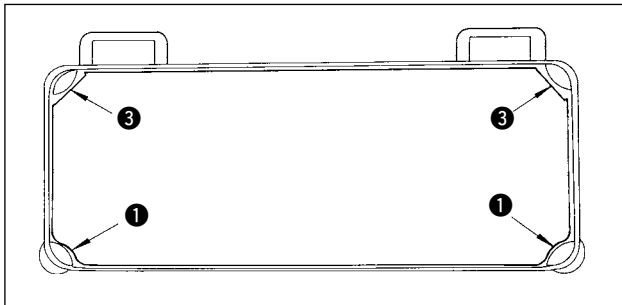

(1) Installing the under cover

- 1) The under cover should rest on the four corners of the machine table groove.
- 2) Two rubber seats ① for supporting the head portion on the operator side A are fixed on the extended portion of the table by hitting the nail ②, and the other two rubber cushion seats ③ on the hinge side B are fixed by using a rubber-based adhesive. Then, oil pan ④ is placed.
- 3) Fit hinge ① into the opening in the machine bed, and fit the machine head to table rubber hinge ② before placing the machine head on cushions ③ on the four corners.

3. INSTALLING THE BELT COVER AND THE BOBBIN WINDER



WARNING :

To protect against possible personal injury due to abrupt start of the machine, be sure to start the following work after turning the power off and ascertaining that the motor is at rest.

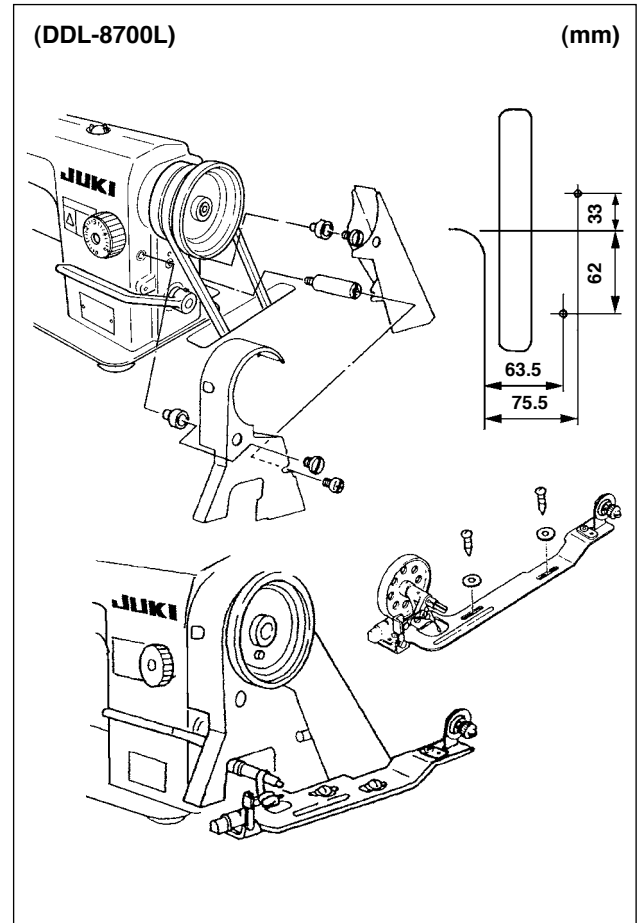
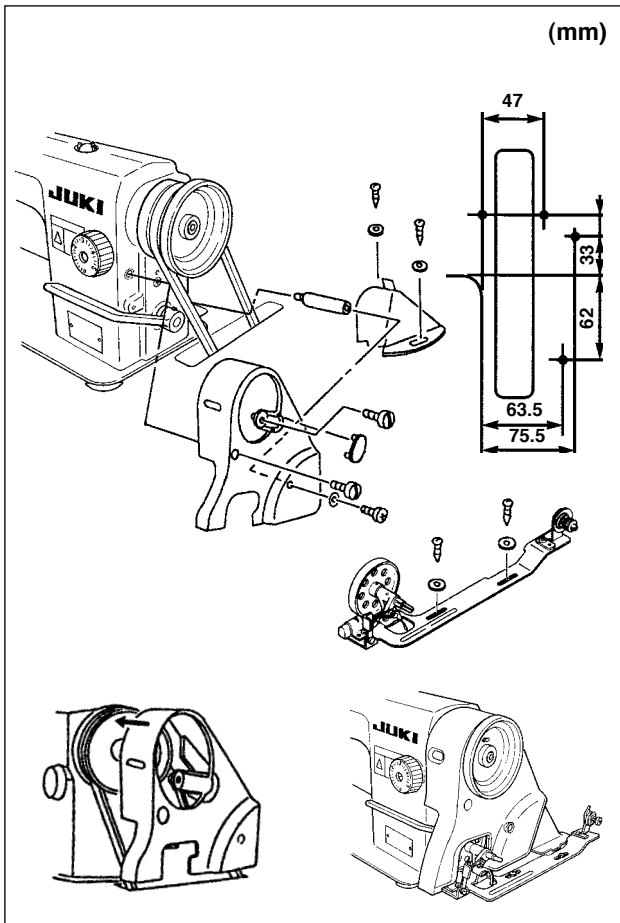

4. ADJUSTING THE HEIGHT OF THE KNEE LIFTER



WARNING :

To protect against possible personal injury due to abrupt start of the machine, be sure to start the following work after turning the power off and ascertaining that the motor is at rest.

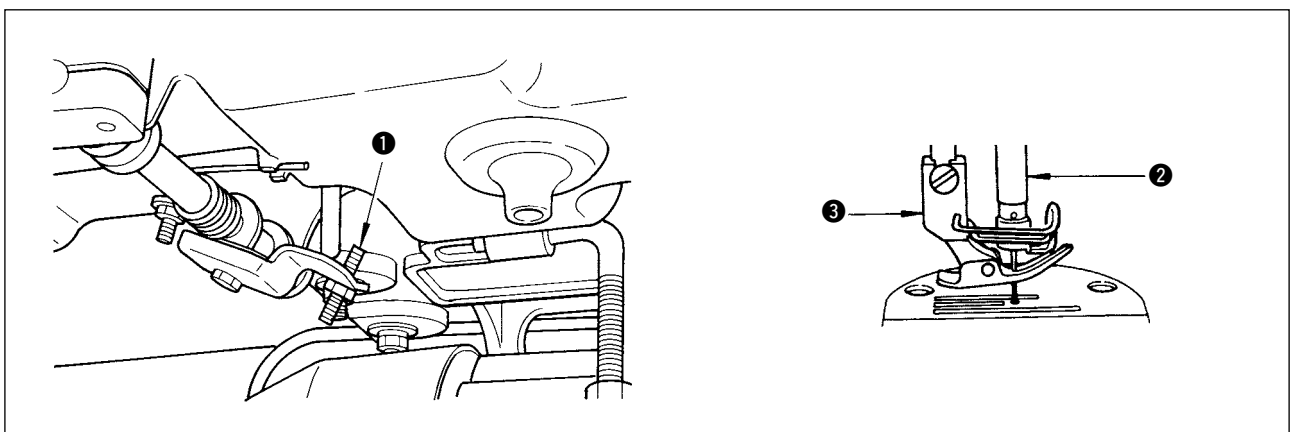

- 1) The standard height of the presser foot lifted using the knee lifter is 10 mm.
- 2) You can adjust the presser foot lift up to 13 mm using knee lifter adjust screw ①. (Max. 9 mm for A type)
- 3) When you have adjusted the presser foot lift to over 10 mm, be sure that the bottom end of needle bar ② in its lowest position does not hit presser foot ③.

5. INSTALLING THE THREAD STAND

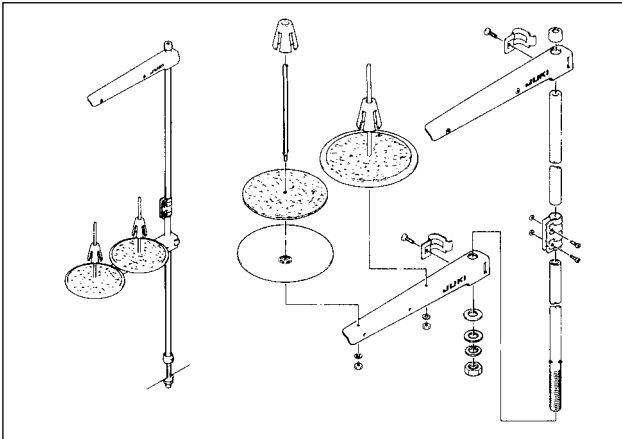

6. LUBRICATION



WARNING :

To protect against possible personal injury due to abrupt start of the machine, be sure to start the following work after turning the power off and ascertaining that the motor is at rest.

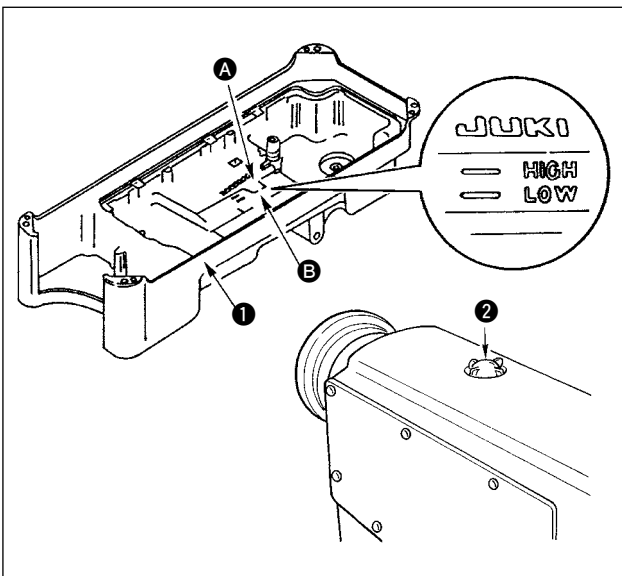

(1) Information on lubrication

- 1) Fill oil pan ① with JUKI New Defrix Oil No. 1 up to HIGH mark ①.
- 2) When the oil level lowers below LOW mark ②, refill the oil pan with the specified oil.
- 3) When you operate the machine after lubrication, you will see splashing oil through oil sight window ② if the lubrication is adequate.
- 4) Note that the amount of the splashing oil is unrelated to the amount of the lubricating oil.



When you first operate your machine after setup or after an extended period of disuse, run your machine at 3,000 sti/min. for about 10 minutes for the purpose of break-in.

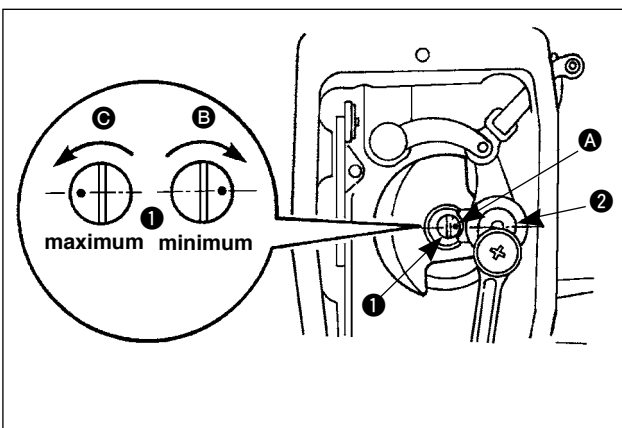

(2) Adjusting the amount of oil supplied to the face plate parts

- 1) Adjust the amount of oil supplied to the thread take-up and needle bar crank ② by turning adjust pin ①.
- 2) The minimum amount of oil is reached when marker dot ① is brought close to needle bar crank ② by turning the adjust pin in direction ②.
- 3) The maximum amount of oil is reached when marker dot ① is brought to the position just opposite from the needle bar crank by turning the adjust pin in direction ③.

7. ADJUSTING THE AMOUNT OF OIL (OIL SPLASHES) IN THE HOOK



WARNING :

Be extremely careful about the operation of the machine since the amount of oil has to be checked by turning the hook at a high speed.

① Amount of oil (oil splashes) confirmation paper

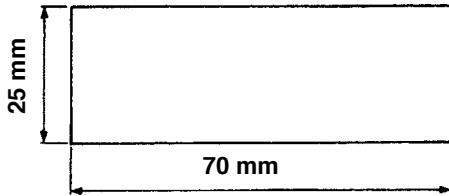

Oil splashes confirmation paper

② Position to confirm the amount of oil (oil splashes)

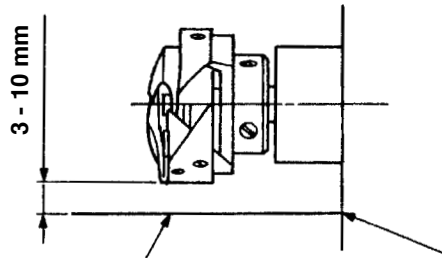

Closely fit the paper against the wall surface of the bed.

* When carrying out the procedure described below in 2, remove the slide plate and take extreme caution not to allow your fingers to come in contact with the hook.

- 1) If the machine has not been sufficiently warmed up for operation, make the machine run idle for approximately three minutes. (Moderate intermittent operation)
- 2) Place the amount of oil (oil spots) confirmation paper under the hook immediately after the machine stops running.
- 3) Confirm the height of the oil surface in the oil reservoir is within the range between "HIGH" and "LOW".
- 4) Confirmation of the amount of oil should be completed in five seconds. (Check the period of time with a watch.)

● Sample showing the appropriate amount of oil

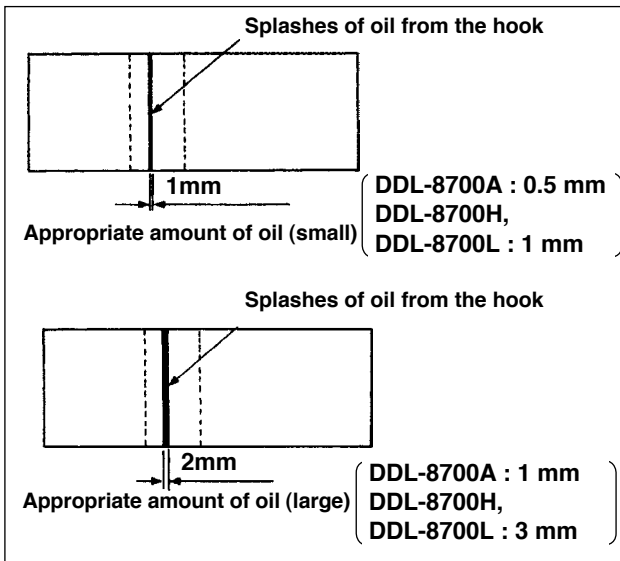

- 1) The amount of oil shown in the samples on the left should be finely adjusted in accordance with sewing processes.

Be careful not to excessively increase/decrease the amount of oil in the hook. (If the amount of oil is too small, the hook will be seized (the hook will be hot). If the amount of oil is too much, the sewing product may be stained with oil.)

- 2) Adjust the amount of oil in the hook so that the oil amount (oil splashes) should not change while checking the oil amount three times (on the three sheets of paper).

● Adjusting the amount of oil (oil spots) in the hook

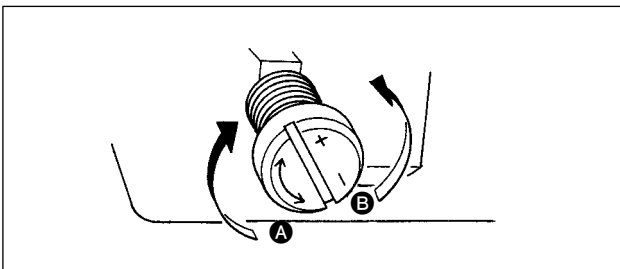

- 1) Turning the oil amount adjustment screw attached on the hook driving shaft front bushing in the "+" direction (in direction **A**) will increase the amount of oil (oil spots) in the hook, or in the "-" direction (in direction **B**) will decrease it.
- 2) After the amount of oil in the hook has been properly adjusted with the oil amount adjustment screw, make the sewing machine run idle for approximately 30 seconds to check the amount of oil in the hook.

8. ATTACHING THE NEEDLE



WARNING :

To protect against possible personal injury due to abrupt start of the machine, be sure to start the following work after turning the power off and ascertaining that the motor is at rest.

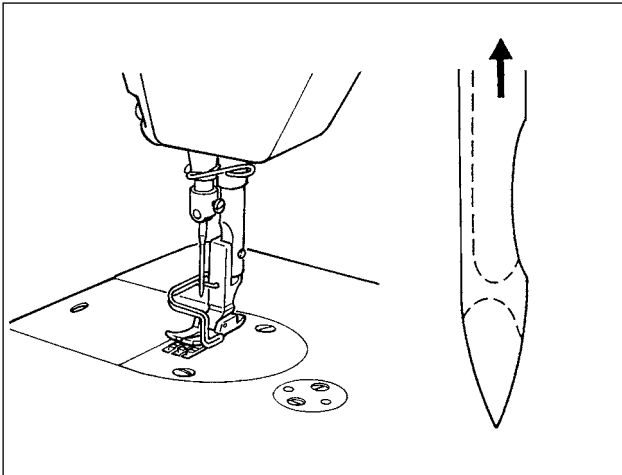

9. SETTING THE BOBBIN INTO THE BOBBIN CASE

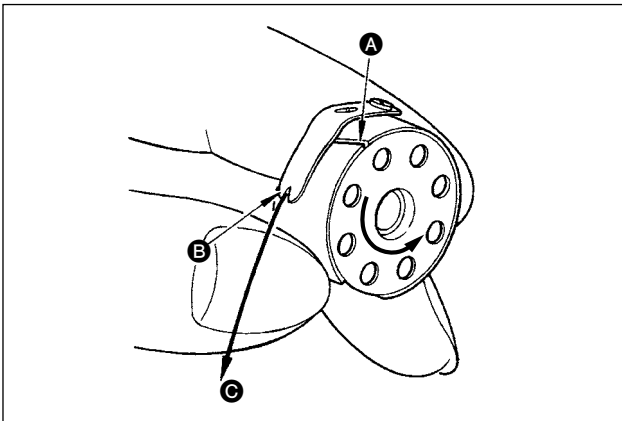

- 1) Pass the thread through thread slit **A**, and pull the thread in direction **B**.

By so doing, the thread will pass under the tension spring and come out from notch **B**.

- 2) Check that the bobbin rotates in the direction of the arrow when thread **C** is pulled.

10. ADJUSTING THE STITCH LENGTH

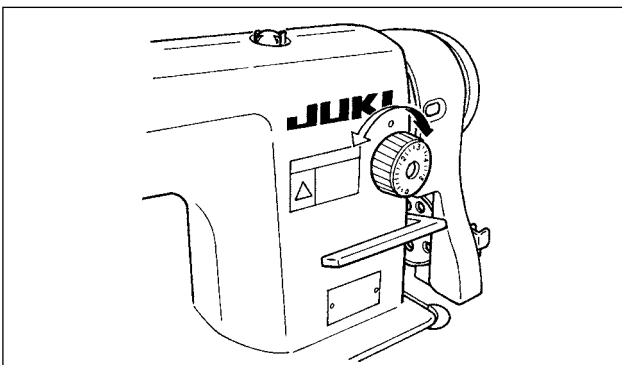

11. PRESSER FOOT PRESSURE

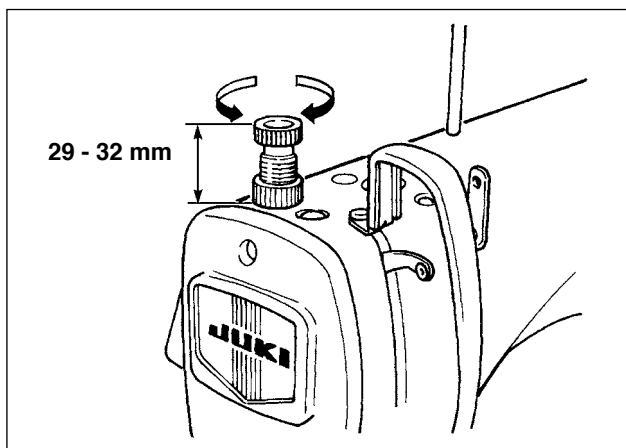

12. HAND LIFTER

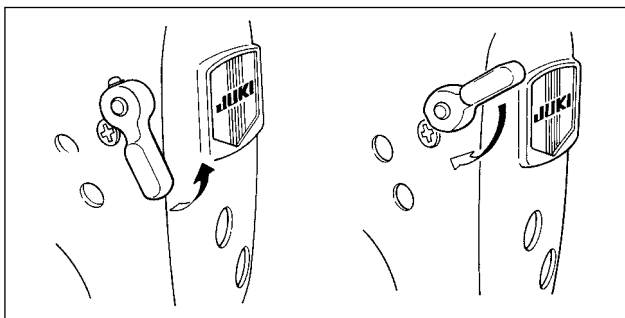

13. ADJUSTING THE HEIGHT OF THE PRESSER BAR



WARNING :

To protect against possible personal injury due to abrupt start of the machine, be sure to start the following work after turning the power off and ascertaining that the motor is at rest.

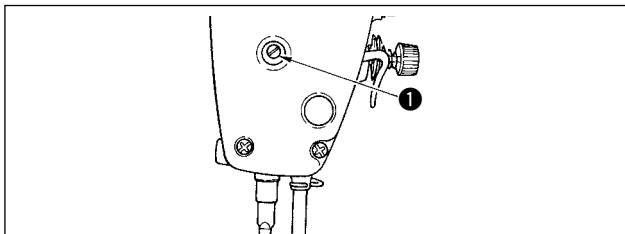

- 1) Loosen setscrew ❶, and adjust the presser bar height or the angle of the presser foot.
- 2) After adjustment, securely tighten the setscrew ❶.

14. THREADING THE MACHINE HEAD



WARNING :

To protect against possible personal injury due to abrupt start of the machine, be sure to start the following work after turning the power off and ascertaining that the motor is at rest.

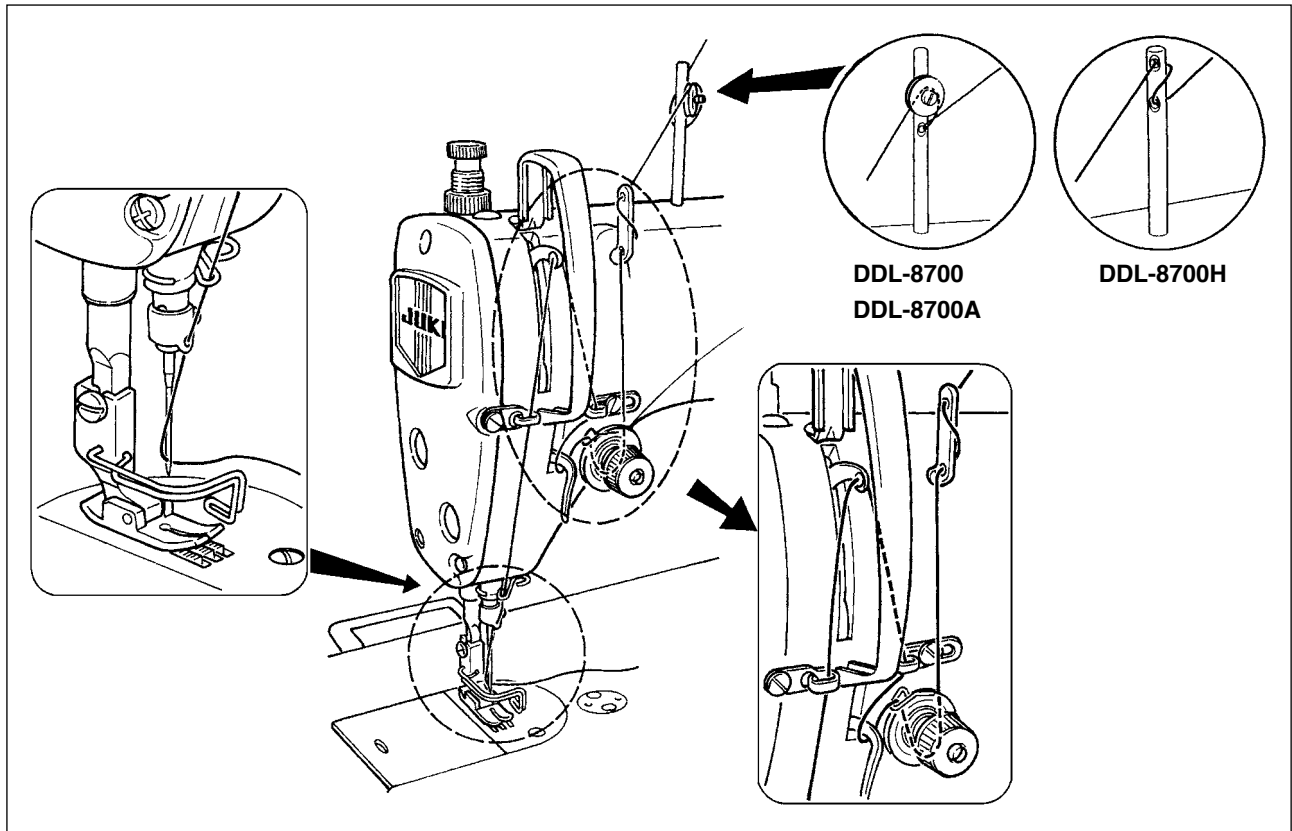

[DDL-8700L]

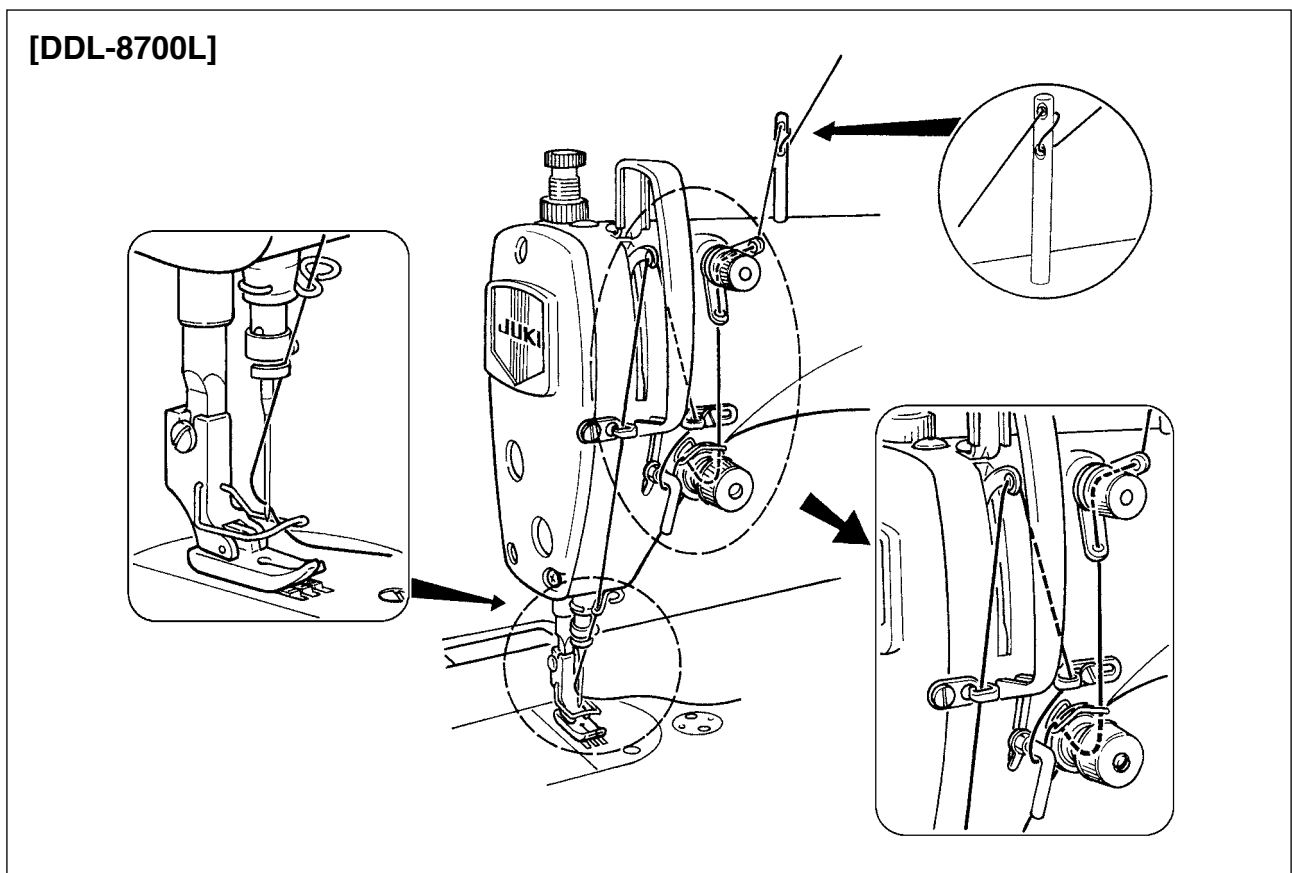

15. THREAD TENSION

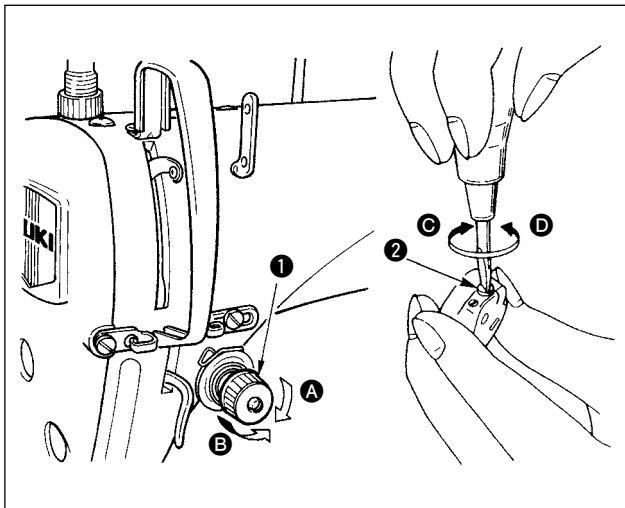

(1) Adjusting the needle thread tension

- 1) As you turn thread tension nut ① clockwise (in direction A), the needle thread tension will be increased.
- 2) As you turn nut ① counterclockwise (in direction B), the needle thread tension will be decreased.

(2) Adjusting the bobbin thread tension

- 1) As you turn tension adjust screw ② clockwise (in direction C), the bobbin thread tension will be increased.
- 2) As you turn screw ② counterclockwise (in direction D), the bobbin thread tension will be decreased.

16. THREAD TAKE-UP SPRING

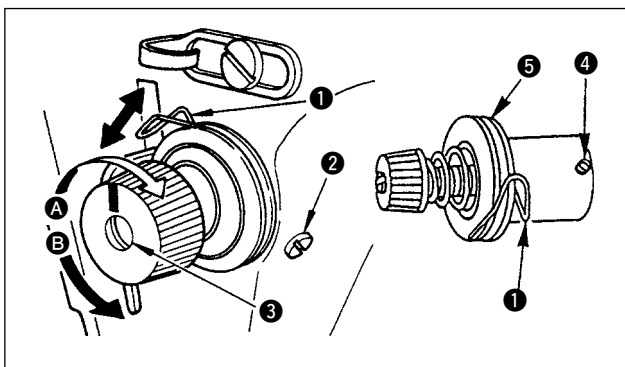

(1) Changing the stroke of thread take-up spring ①

- 1) Loosen setscrew ②.
- 2) As you turn tension post ③ clockwise (in direction A), the stroke of the thread take-up spring will be increased.
- 3) As you turn the knob counterclockwise (in direction B), the stroke will be decreased.

(2) Changing the pressure of thread take-up spring ①

- 1) Loosen setscrew ②, and remove tension post ③.
- 2) Loosen setscrew ④.
- 3) As you turn tension post ③ clockwise (in direction A), the pressure will be increased.
- 4) As you turn the tension post counterclockwise (in direction B), the pressure will be decreased.

17. ADJUSTING THE THREAD TAKE-UP STROKE



WARNING :

To protect against possible personal injury due to abrupt start of the machine, be sure to start the following work after turning the power off and ascertaining that the motor is at rest.

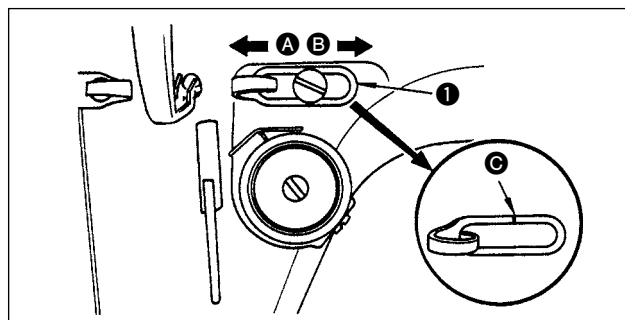

- 1) When sewing heavy-weight materials, move thread guide ① to the left (in direction A) to increase the length of thread pulled out by the thread take-up.
- 2) When sewing light-weight materials, move thread guide ① to the right (in direction B) to decrease the length of thread pulled out by the thread take-up.
- 3) Normally, thread guide ① is positioned in a way that marker line C is aligned with the center of the screw.

18. NEEDLE-TO-HOOK RELATIONSHIP



WARNING :

To protect against possible personal injury due to abrupt start of the machine, be sure to start the following work after turning the power off and ascertaining that the motor is at rest.

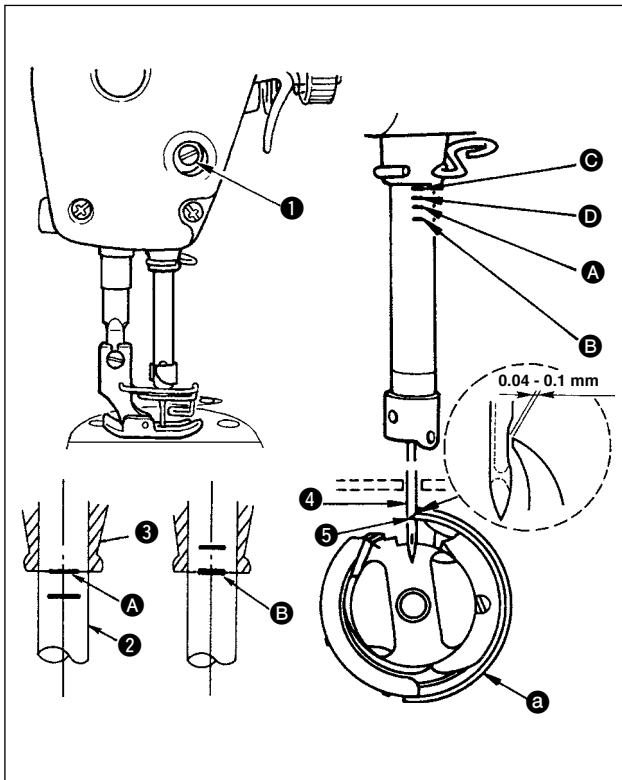

(1) Adjust the timing between the needle and the hook as follows :

- 1) Turn the handwheel to bring the needle bar down to the lowest point of its stroke, and loosen setscrew ①.

(Adjusting the needle bar height)

- 2) (For a DB needle) Align marker line A on needle bar ② with the bottom end of needle bar lower bushing ③, then tighten setscrew ①.

(For a DA needle) Align marker line C on needle bar ② with the bottom end of needle bar lower bushing ③, then tighten setscrew ①.

(Adjusting position of the hook a)

- 3) (For a DB needle) Loosen the three hook setscrews, turn the handwheel and align marker line B on ascending needle bar ② with the bottom end of needle bar lower bushing ③.

(For a DA needle) Loosen the three hook setscrews, turn the handwheel and align marker line D on ascending needle bar ② with the bottom end of needle bar lower bushing ③.

- 4) After making the adjustments mentioned in the above steps, align hook blade point ⑤ with the center of needle ④. Provide a clearance of 0.04 mm to 0.1 mm (DDL-8700H, 8700L : 0.06 to 0.17mm) (reference value) between the needle and the hook, then securely tighten setscrews in the hook.



If the clearance between the blade point of hook and the needle is smaller than the specified value, the blade point of hook will be damaged. If the clearance is larger, stitch skipping will result.

19. HEIGHT OF THE FEED DOG



WARNING :

To protect against possible personal injury due to abrupt start of the machine, be sure to start the following work after turning the power off and ascertaining that the motor is at rest.

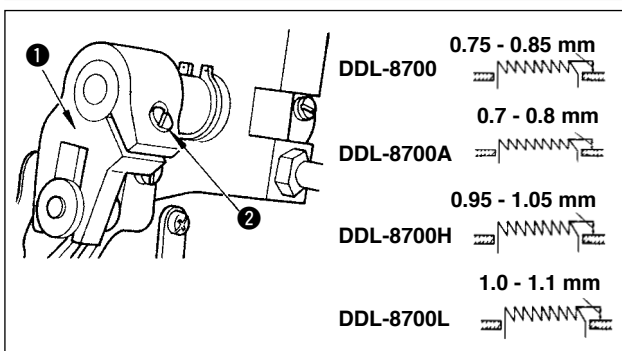

To adjust the height of the feed dog :

- ① Loosen screw ② of crank ①.
- ② Move the feed bar up or down to make adjustment.
- ③ Securely tighten screw ②.



If the clamping pressure is insufficient, the motion of the forked portion becomes heavy.

20. TILT OF THE FEED DOG



WARNING :

To protect against possible personal injury due to abrupt start of the machine, be sure to start the following work after turning the power off and ascertaining that the motor is at rest.

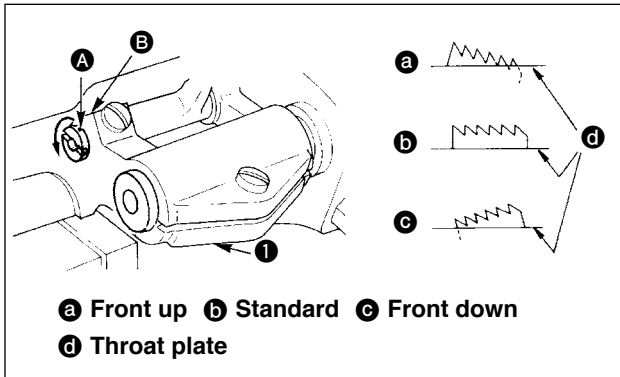

- 1) The standard tilt (horizontal) of the feed dog is obtained when marker dot **A** on the feed bar shaft is aligned with marker dot **B** on feed rocker **1**. (DDL-8700H, the marker dot **B** inclines forward the feed rocker shaft by 90°, as standard).
- 2) To tilt the feed dog with its front up in order to prevent puckering, loosen the setscrew, and turn the feed bar shaft 90° in the direction of the arrow, using a screwdriver.
- 3) To tilt the feed dog with its front down in order to prevent uneven material feed, turn the feed bar shaft 90° in the opposite direction from the arrow. (The standard tilt for DDL-8700H.)



Whenever the feed dog tilt is adjusted, the feed dog height will be changed. So, it is necessary to check the height after tilt adjustment.

21. ADJUSTING THE FEED TIMING



WARNING :

To protect against possible personal injury due to abrupt start of the machine, be sure to start the following work after turning the power off and ascertaining that the motor is at rest.

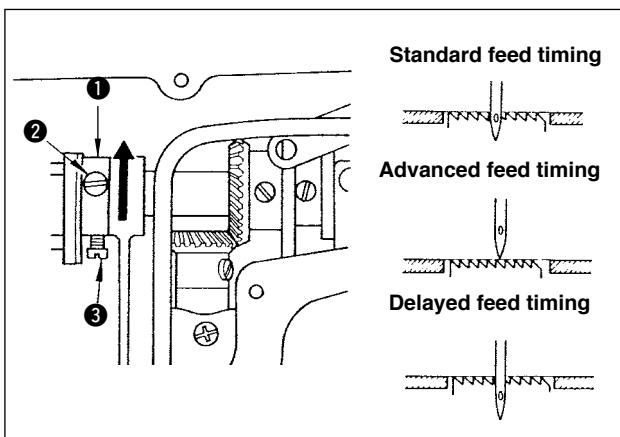

- 1) Loosen screws **2** and **3** in feed eccentric cam **1**, move the feed eccentric cam in the direction of the arrow or opposite direction of the arrow, and firmly tighten the screws.
- 2) For the standard adjustment, adjust so that the top surface of feed dog and the top end of needle eyelet are flush with the top surface of throat plate when the feed dog descends below the throat plate.
- 3) To advance the feed timing in order to prevent uneven material feed, move the feed eccentric cam in the direction of the arrow.
- 4) To delay the feed timing in order to increase stitch tightness, move the feed eccentric cam in the opposite direction from the arrow.



Be careful not to move the feed eccentric cam too far, or else needle breakage may result.

22. ADJUSTING THE FEED TIMING (DDL-8700L)



WARNING :

To protect against possible personal injury due to abrupt start of the machine, be sure to start the following work after turning the power off and ascertaining that the motor is at rest.

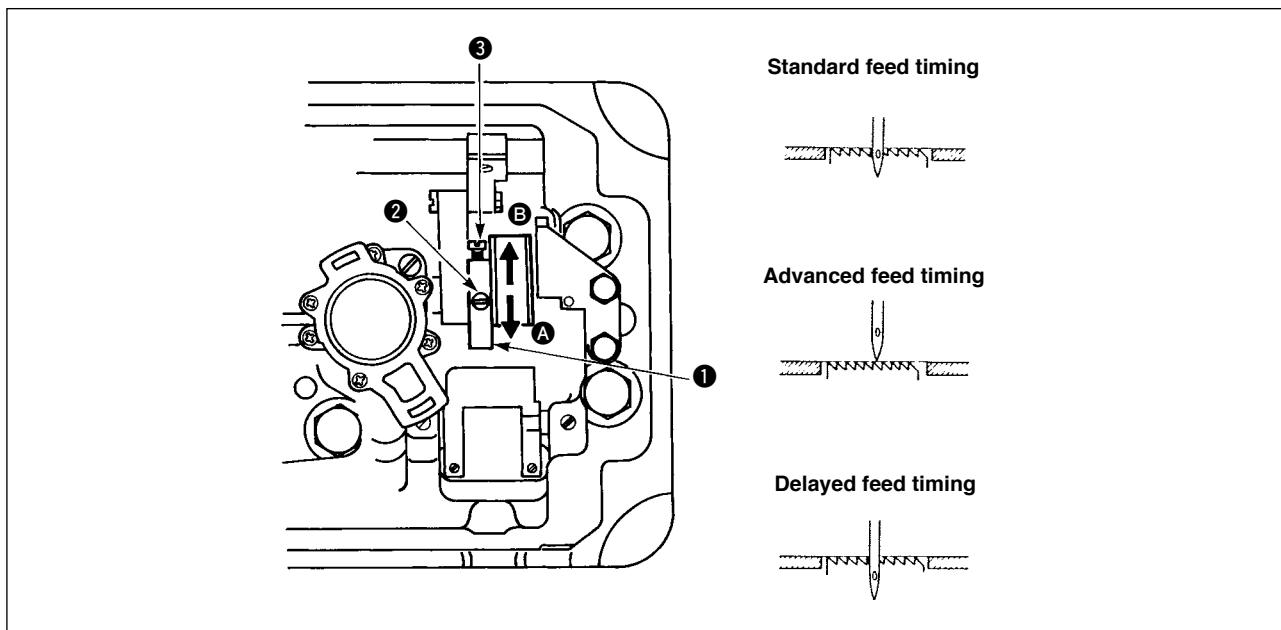

- 1) Tilt the machine head and insert a screwdriver from the bottom side of the machine head.
- 2) Loosen plated screws ② and ③ in feed eccentric cam ①, move screw ② in the direction of the arrow, and firmly tighten screw ②. Then tighten screw ③.
- 3) For the standard adjustment, adjust so that the top surface of feed dog and the top end of needle eyelet are flush with the top surface of throat plate when the feed dog descends below the throat plate.
- 4) To advance the feed timing in order to prevent uneven material feed, move the feed eccentric cam in the direction of **A**.
- 5) To delay the feed timing in order to increase stitch tightness, move the feed eccentric cam in the direction of **B**.



- Be careful not to move the feed eccentric cam too far, or else needle breakage may result.
- When loosening the screws in the feed eccentric cam, if the feed eccentric cam is not properly adjusted in lateral direction, torque of the sewing machine or seizure of the feed eccentric cam may result.

23. MOTOR PULLEYS AND BELTS

- 1) A clutch motor with 400W output (1/2 HP) is used as the standard motor.
- 2) An M-type V belt should be used.
- 3) The relationship between the motor pulleys, belt lengths and sewing speeds is shown in the following table :

Motor pulley O.D. (mm)	Motor pulley part No.	Sewing speed (rpm)		Belt length	Belt part No.
		50 Hz	60 Hz		
125	MTKP0120000	5,060		1118 mm (44")	MTJVM004400
120	MTKP0115000	4,850		1092 mm (43")	MTJVM004300
115	MTKP0110000	4,630			
110	MTKP0105000	4,440			
105	MTKP0100000	4,250	5,040	1067 mm (42")	MTJVM004200
100	MTKP0095000	4,000	4,780		
95	MTKP0090000	3,820	4,540		
90	MTKP0085000	3,610	4,320		
85	MTKP0080000	3,390	4,000	1041 mm (41")	MTJVM004100
80	MTKP0075000	3,160	3,790		
75	MTKP0070000	2,950	3,520		
70	MTKP0065000	2,740	3,260		

- * The effective diameter of a motor pulley is equivalent to the outside diameter minus 5 mm.
- * The motor should rotate counterclockwise as observed from the handwheel side. Be careful not to allow the motor to rotate in the reverse direction.